

JBL

PROFESSIONAL

Control[®] 29AV

High Output Indoor/ Outdoor Monitor Speaker

Professional Series

Key Features:

- ▶ Extended bandwidth, extremely smooth frequency response.
- ▶ 110° x 85° HF coverage, rotatable horn.
- ▶ 110 Watt transformer for 70V or 100V lines, with 8Ω thru.
- ▶ SonicGuard™ overload protection.
- ▶ 200 mm (8") Kevlar cone woofer, 25 mm (1") titanium diaphragm compression driver.
- ▶ Includes InvisiBall™ mounting hardware, plus ten 6 mm attachment points for suspension and optional U-bracket.
- ▶ Sealed input panel cover and screw-down input terminals.

The Control[®] 29AV utilizes high power components, computer optimized horn and cabinet design and complex network to achieve smooth high fidelity performance, extended bandwidth and well-controlled defined coverage from a compact loudspeaker.

A rotatable high-frequency horn allows use of the speaker in either vertical or horizontal orientation. Smooth frequency response and even coverage ensures excellent sound character throughout the listening area. Partial magnetic shielding allows use of the speaker as close as 230 mm (9") to video monitors.

The top-quality line distribution transformer, designed for minimal insertion loss and reduced saturation, allows use of either 70V or 100V distributed speaker lines. In bypass position, the high 8Ω impedance allows use of multiple speakers on a loudspeaker line.

The included InvisiBall mounting method is simple to install, aims easily and provides a high degree of theft deterrence. InvisiBall allows horizontal rotation of up to 41° off-axis and vertical rotation of up to 36° (horn end inward) or 23° (woofer end inward). Attachment points for the optional MTC-29UB U-bracket allows for compact installation and is particularly useful for low profile underbalcony applications.

Weather resistance has been maximized. The woofer's cone is made of kevlar, surround is pure butyl rubber, and the driver basket is rear loaded to minimize direct exposure. The compression driver's diaphragm is pure titanium. The grille is thermoset composite coated and comes with foam to minimize incursion of water. Nickel/zinc rust-resistant terminals ensure a secure input connection. An MTC-PC2 sealed-entrance cover is included to further protect the speaker's terminals.

JBL's exclusive SonicGuard overload protection is virtually inaudible to the listener, ensuring reliability while providing full fidelity sound.



Available in black or white (-WH). The cabinet will accept a variety of paints to match any décor.

Specifications:

Frequency Range (-10 dB) ¹ :	40 Hz –19 kHz
Frequency Response (± 3 dB) ¹ :	45 Hz – 18 kHz
100 Hr Power Capacity ² :	300 Watts Continuous Program Power 150 Watts Continuous Pink Noise
Maximum SPL @ 1m ³ :	Short-Term: 120 dB; Long-Term: 114 dB
Nominal Sensitivity ⁴ :	91 dB, 1W @ 1 m (3.3 ft)
Nominal Coverage Angle ⁵ :	110° H x 85° V, rotatable
Directivity Factor (Q):	7.2, averaged 500 Hz to 16 kHz
Directivity Index (DI):	8.6 dB, averaged 500 Hz to 16 kHz
Nominal Impedance:	8 ohms
Minimum Impedance:	6.3 ohms @ 230 Hz
Crossover Type:	3rd order High Pass, 2nd order Low Pass with impedance compensation, 2.5 kHz crossover frequency
Transformer Taps:	70V: 110W, 55W, 28W & 14W 100V: 110W, 55W, & 28W Thru Position: 8Ω nominal
Recommended High-Pass:	See chart
Transducers:	
Low Frequency:	200 (8 in) kevlar cone with pure butyl rubber surround, 50 mm (2 in) voicecoil on fiberglass former
High Frequency:	25 mm (1 in) compression driver, pure titanium diaphragm with patented JBL diamond surround
Physical:	
Enclosure Material:	High impact polystyrene
Grille:	Thermoset composite coated steel
Overload Protection:	Full-range power limiting to protect network and transducers. Serviceable internal fuse to protect during exceptional overload conditions.
Environmental:	IEC 529 IP-X4 splashproof rating. Exceeds MilSpec 810 for humidity, salt spray, temperature & UV. Passes Mil-Std-202F for salt spray.
Termination:	Screw-down terminal strip, zinc plated copper base, nickel plated metal screws/washers. Accepts up to 9 mm outside 4 mm inside open lug (#6, #8 or #10 lug), plus bare wire (up to 12 AWG/2.5 mm ²).
Safety Agency Rating:	Transformer is listed per UL1876.
Colors:	Black or white (-WH)
Dimensions (H x W x D):	520 x 306 x 277 mm (20.5 x 12.0 x 10.9 in)
Net Weight (ea):	12.2 kg (26.8 lbs)
Shipping Weight (ea):	14.0 kg (30.8 lbs)
Included Accessories:	1 pc MTC-PC2 input panel cover, InvisiBall mounting base, 6 mm x 260 mm InvisiBall Hex wrench.
Optional Accessories:	MTC-29CM to install speaker down from the ceiling MTC-29UB U-bracket

¹ In Half-space.

² Continuous Pink Noise rating is IEC-shaped pink noise with a 6 dB crest factor for 100 hours continuously. Continuous program power is defined as 3 dB above the Continuous Pink Noise Rating and is a conservative expression of the system's ability to handle normal speech and music program material.

³ Calculated from sensitivity and power handling. Power compression not considered.

⁴ Half-space, averaged 100 Hz to 10 kHz ⁵ 2 kHz to 14 kHz

JBL continually engages in research related to product improvements. Changes introduced into existing products without notice are an expression of that philosophy.

Control® 29AV High Output Indoor/Outdoor Monitor Speaker

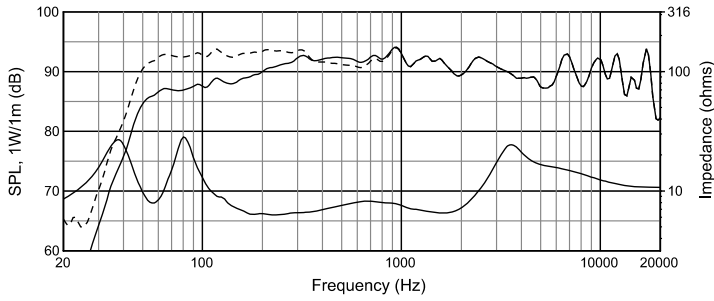

Frequency Response, on axis in half space (2π , dotted line) and full space (4π , solid line) at thru (8Ω) setting, Input Impedance.

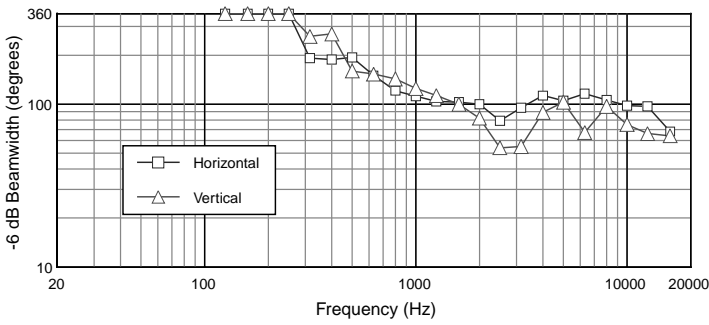

Beamwidth vs. Frequency

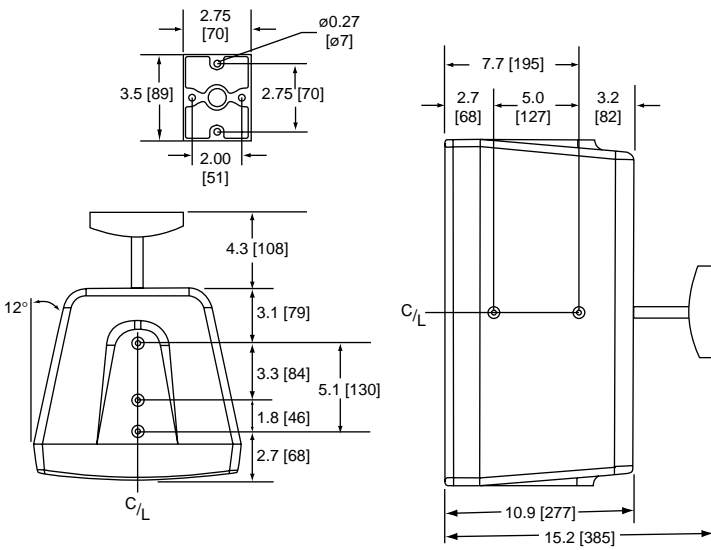

Directivity Index, Q

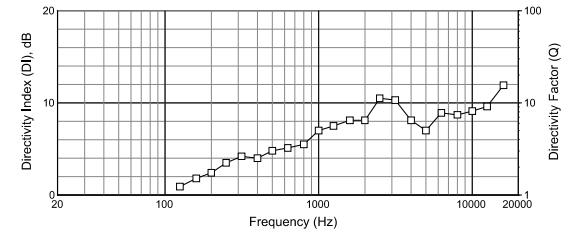

Horizontal Off Frequency

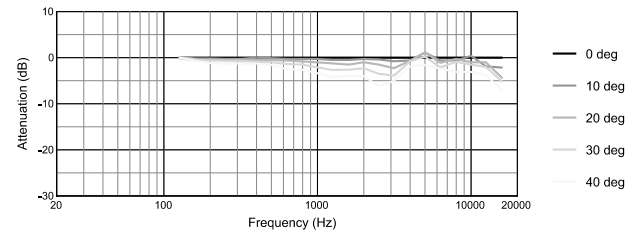

Vertical Off Axis Frequency Response (down)

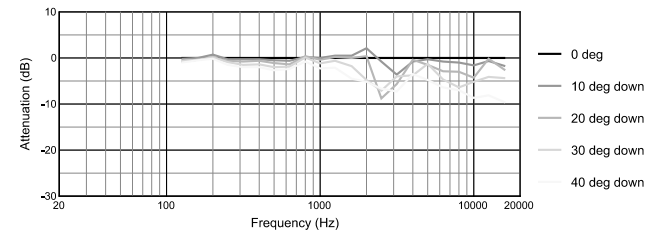

Vertical Off Axis Frequency Response (up)

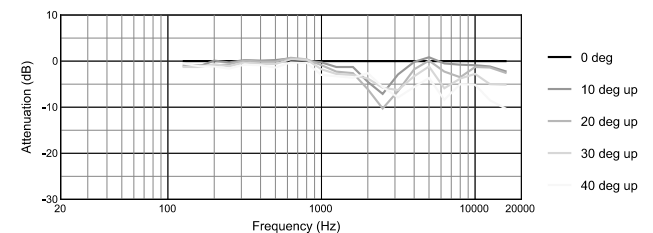

Horizontal 1/3 Octave Polars

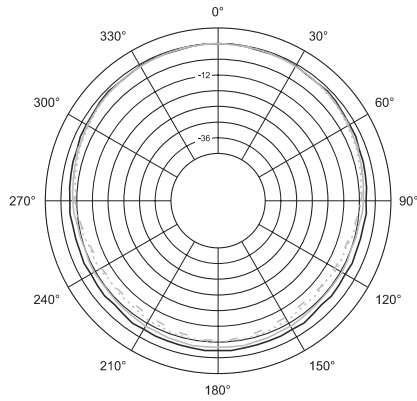

— 200Hz
— 250Hz
..... 315Hz
- - 400Hz

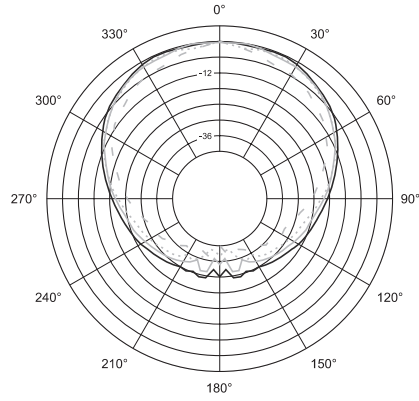

— 8kHz
— 10kHz
..... 12.5kHz
- - 16kHz

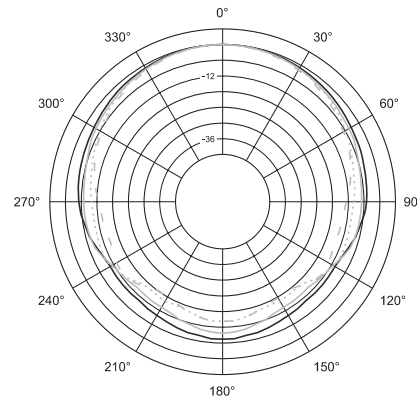

— 500Hz
— 630Hz
..... 800Hz
- - 1kHz

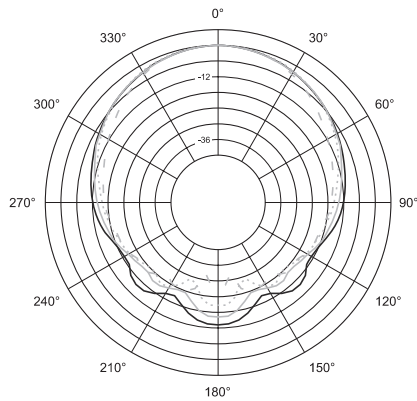

— 1.25kHz
— 1.6kHz
..... 2kHz
- - 2.5kHz

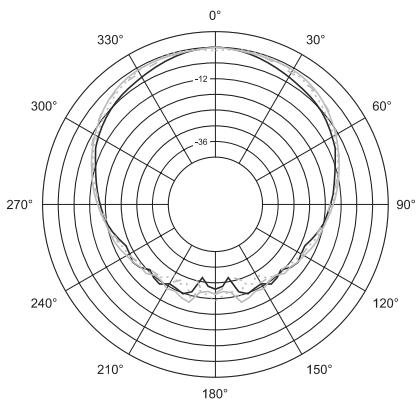

— 3.15kHz
— 4kHz
..... 5kHz
- - 6.3kHz

Architectural Specifications:

The loudspeaker shall consist of a 200 mm (8 in) low frequency transducer, 25 mm (1 in) compression driver, and frequency dividing network. The low frequency driver's voice coil shall be 50 mm (2 in) in diameter.

Performance specifications of a typical unit shall be as follows: Usable frequency response shall extend from 40 Hz to 18 kHz (10 dB below rated sensitivity, half-space, no external equalization). Rated power shall be at least 300 watts continuous program power for 100 continuous hours duration (defined as 3 dB above a test signal of filtered random pink noise conforming to IEC268-5). Measured sensitivity shall be at least 91 dB-SPL (at 1 m [3.3 ft] with 2.83 V input, ave. 100 Hz to 10 kHz).

The input shall be switchable for use either at nominal 8 ohms, or on a 70.7V or 100V distributed speaker line via built-in transformer. Selectable taps shall nominally be 110W, 55W, or 28W on either a 70.7V or 100V distributed speaker line, plus 14W on 70.7V line only.

The system shall be protected against damage from occasional overpowering via full range limiting, which shall be inaudible during activation. The compression driver shall be horn-loaded to cover 110 degrees by 85 degrees with a high degree of accuracy and the horn shall be rotatable to achieve these coverages either in the horizontal or vertical planes, regardless of cabinet orientation.

The cabinet and grille shall be paintable. The grille shall be secured via screws to keep it in place when facing downward.

The low frequency transducer shall have woven kevlar cone and butyl rubber surround, with the frame protected from direct weather exposure. The compression driver shall be constructed with a titanium diaphragm for weather resistance. The system shall withstand Mil Spec 810 testing with specified durations with no effect on its acoustical performance or structural integrity: salt spray (method 509.3), temperature (method 501.3 and 502.3), humidity (method 507.3) and ultraviolet (method 505.3). Further, it shall pass Mil-Std-202F (method 101D) for salt spray. The system shall have an IEC 529 splashproof rating of IP-X4.

For theft-deterrence, the installation access area shall be hidden behind a snap-out cover on the front grille. The included ball mechanism shall be internal to the cabinet. The cabinet shall have ten (10) 6 mm mounting points, including 2 on each side and 3 on top and bottom and an accessory U-bracket shall be available. The grille logo shall be rotatable for proper orientation with loudspeaker mounted horizontally or vertically.

The external wiring connectors shall be screw-down terminals. Overall cabinet dimensions shall be no greater than 520 mm high x 306 mm wide x 277 mm deep (20.5 x 12.0 x 10.9 in) and shall weigh no more than 12.2 kg (26.8 lb). The finish shall be lightly textured black or white.

The system shall be the JBL Model Control 29AV (or Control 29AV-WH) with included InvisiBall® (mounting system).

Control[®] 29AV High Output Indoor/Outdoor Monitor Speaker

Vertical 1/3 Octave Polars

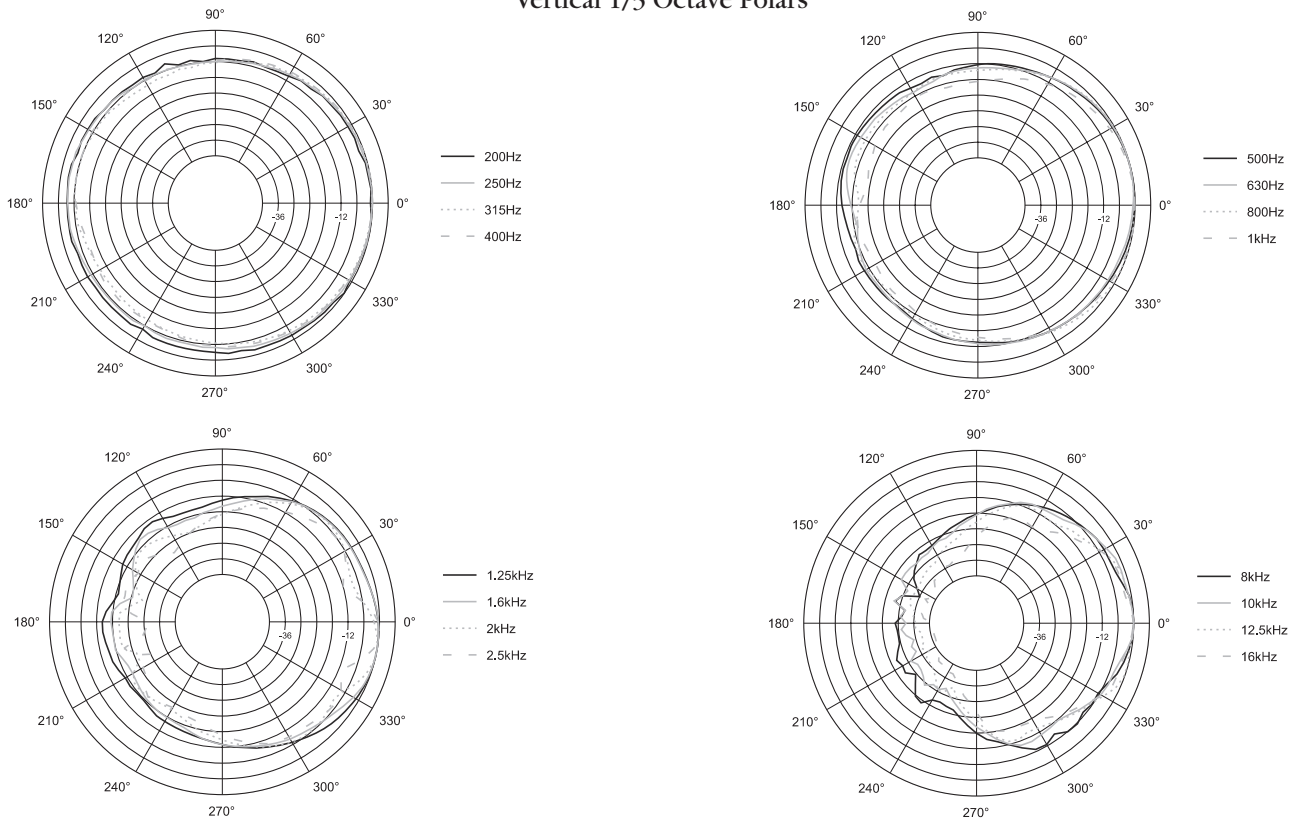

High-Pass Frequency Recommendations

The transformer in Control 29AV has been designed to minimize transformer saturation, however it is recommended that when driving the transformer settings with very high signal levels, that the system be high-passed to prevent excessive low frequency content from overloading the transformer and stressing the driving amplifier. The high-pass frequency requirements vary according to the tap setting and how many speakers are connected in parallel. The following chart assumes the goal of totally eliminating all saturation, even at full-voltage (70V or 100V) peaks. You may be able to lower the high-pass frequency when operating at lower volumes. (High-pass slope is 24 dB/oct)

High-Pass Recommendations for Control 29AV

	1 or 2 speakers	3 or more speakers
14 Watt Tap	30 Hz	35 Hz
28 Watt Tap	35 Hz	40 Hz
55 Watt Tap	60 Hz	70 Hz
110 Watt Tap	80 Hz	90 Hz
8 Ohm Setting	No high-pass required	



JBL Professional
 8500 Balboa Boulevard, P. O. Box 2200
 Northridge, CA 91329 USA
 A Harman International Company

SSCONTROL 29AV
 CRP 10M 2/01